

RD1P0 series integrated 1.0KW

On Board DC-DC converter



Contents

Product Introduction	1
1. Electrical Characteristics	1
1.1. Electrical Characteristics	1
1.2. System Block Diagram	2
1.3. Characteristic Curve	4
2. Dimensions and Weight	5
2.1. Product size	5
2.2. Product Weight	5
3. Definition of connectors and connection terminals	6
3.1. Schematic diagram of signal interface	6
4. User Guide	7
4.1. Electrical Connection Diagram	7
4.2. Product Installation	7
4.3. CAN Communication Protocol	8
4.4. Instructions for backend debugging software	8
4.5. Troubleshooting and Confirmation	8
5. User Notice and Precautions	9
6. Reference standards and specifications	10
7. Packaging, transportation, and storage	11
8. Version update record	12

Product Introduction

The **RD1P0** series in car DC-DC converter is a high-power, high-density, and high-efficiency DC-DC converter developed specifically for new energy vehicle models such as lithium-ion electric vehicles, logistics vehicles, specialized vehicles, and construction machinery. It is designed and developed using modular, standardized, and universal design concepts.

The module is designed using fully digital control technology, with flexible and intelligent control, good protection characteristics, and strong system robustness. The built-in microprocessor communicates with the monitoring unit, and the internal parameters can be set or adjusted by the higher-level monitoring unit through the CAN interface.

It has multiple protection functions such as input overvoltage protection, output overcurrent protection, output overvoltage protection, output short circuit protection, and over temperature protection.

Main specifications:

model	Input Voltage	Rated output power	rated output voltage	Output voltage/current range	3d model
RD1P0048	40~80VDC	1.0KW	14VDC	0-16VDC/0-71A	RD1P00722 V1.2.stp
RD1P0072	50~100VDC	1.0KW	14VDC	0-16VDC/0-71A	
RD1P2144	80~200VDC	1.2KW	14VDC	0-16VDC/0-85A	
RD1P2360	200~450VDC	1.2KW	14VDC	0-16VDC/0-85A	
RD1P2540	400~700VDC	1.2KW	14VDC	0-16VDC/0-85A	
RD1P2144-27	80~200VDC	1.2KW	27VDC	0-32VDC/0-42A	
RD1P2360-27	200~450VDC	1.2KW	27VDC	0-32VDC/0-42A	
RD1P2540-27	400~700VDC	1.2KW	27VDC	0-32VDC/0-42A	

1 Electrical characteristics

1.1 Electrical characteristics

model								
Vehicle power supply type	Self cooling car DC-DC converter							
Model and supplier part number	RD1P004 8	RD1P007 2	RD1P214 4	RD1P23 60	RD1P254 0	RD1P2144 -27	RD1P236 0-27	RD1P254 0-27
Input characteristics								
Rated input voltage	48V	72V	144V	360V	540V	144V	360V	540V
Input Voltage	40~80V	50-100	80-200	200-450	400-700	80-200	200-500	400-700
Input pre charging circuit	built-in							
Input pre charge resistor	30R	30R	30R	120R	120R	30R	120R	120R
Start the impulse current	≤5A							

Bus capacitor	20uF	20uF	20uF	10uF	7uF	20uF	10uF	7uF
output characteristic								
Rated output power	1.0KW		1.2KW		1.2KW			
rated output voltage	14V		14V		27V			
Output voltage range	0~16V		0~16V		0-32V			
Current range	0~71A		0~85A		0~42A			
Voltage stabilization accuracy (lead root test)	± 0.2V (lead root test)				± 0.4V (lead root test)			
Output response time	≤200mS							
Typical Efficiency	≥90%		≥91%		≥92%			
work noise	≤60dB							
Protection features								
Overvoltage and undervoltage protection	Input overvoltage shutdown can self recover, output overvoltage shutdown can self recover.							
Output reverse connection and short circuit protection	Shutdown in case of output short circuit or reverse connection, self recovering							
Over Temperature Protection	When the temperature of the heat sink is higher than 75 °C, reduce the output power. When the temperature is higher than 95 °C, disconnect the circuit. When the charging temperature returns to below 85 °C, the charger will resume output							
environmental condition								
Ambient Temperature	-40°C~+85°C							
storage temperature	-40~95°C							
humidity	5% to 95% non condensing, non condensing							
IP GRADE	IP67							
Cooling function	Self cooling (additional fan may be required)							
communication	can-bus							
control mode	No enable control; Hard wired high-level enable control; CAN communication enables control							
Safety characteristics								
dielectric strength	Primary side - secondary side 2000VAC				Original Edge - Chassis 1500VAC			
insulation resistance	Primary side - secondary side ≥ 50M Ω							
Vibration resistance performance	After conducting frequency sweep vibration tests in X, Y, and Z directions, there was no damage to the components and no loosening of the fasteners							
impact resistance	Refer to the requirements of 6.5 in GB/T15139-1994							
Resistance to industrial solvents	Metal components have a good anti-corrosion layer							
Salt spray resistance performance	Refer to GB/T 2423.17							
durability	Not lower than the relevant provisions of GB/T 24347-2009							
EMC characteristics								

electromagnetic immunity	Meet the requirements of Chapter 4 in GB/T17619-1998
Electromagnetic disturbance	Refer to the limit values specified in Chapter 12 and Chapter 14 of GB18655-2002

1.1 Electrical topology diagram

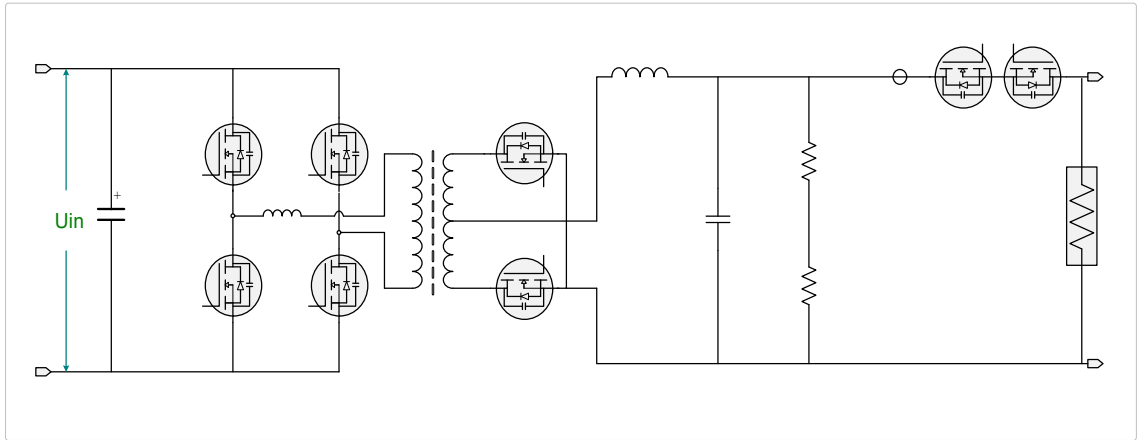

1.2 System Block Diagram

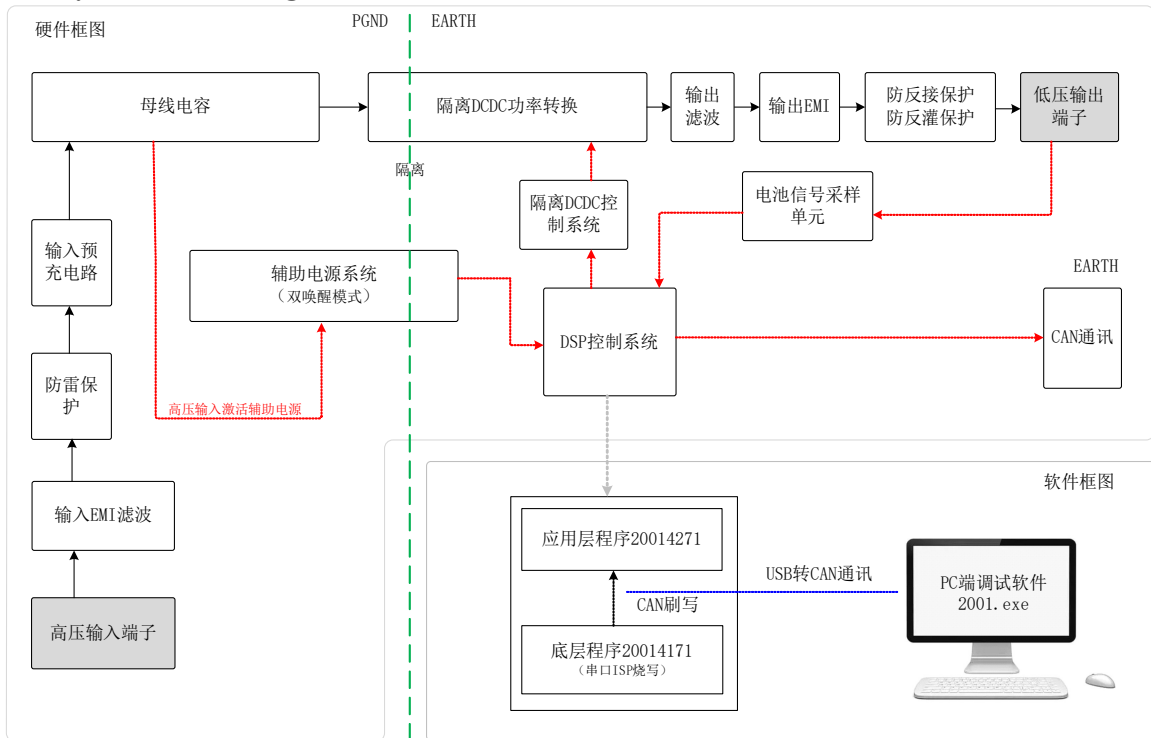

1.3 characteristic curves

RDIP0048 external characteristic curve

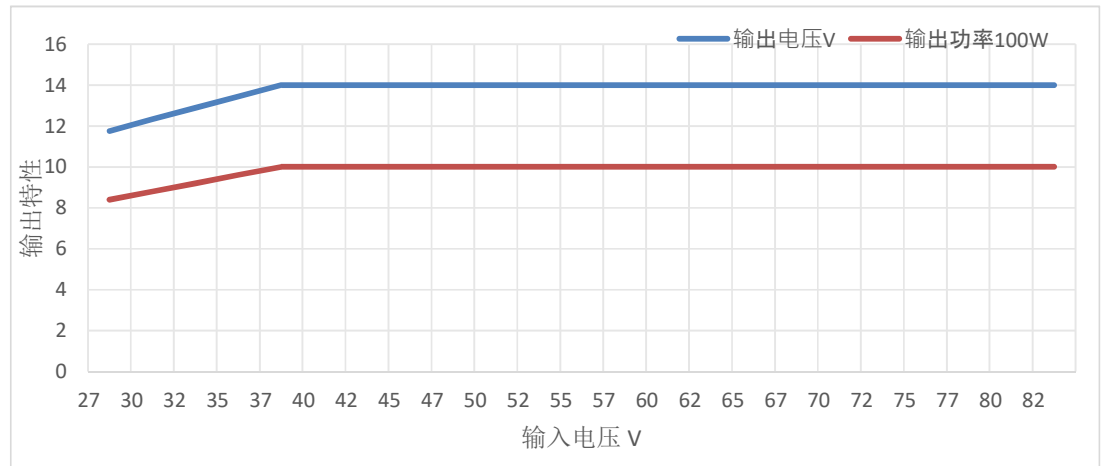

RDIP0072 external characteristic curve

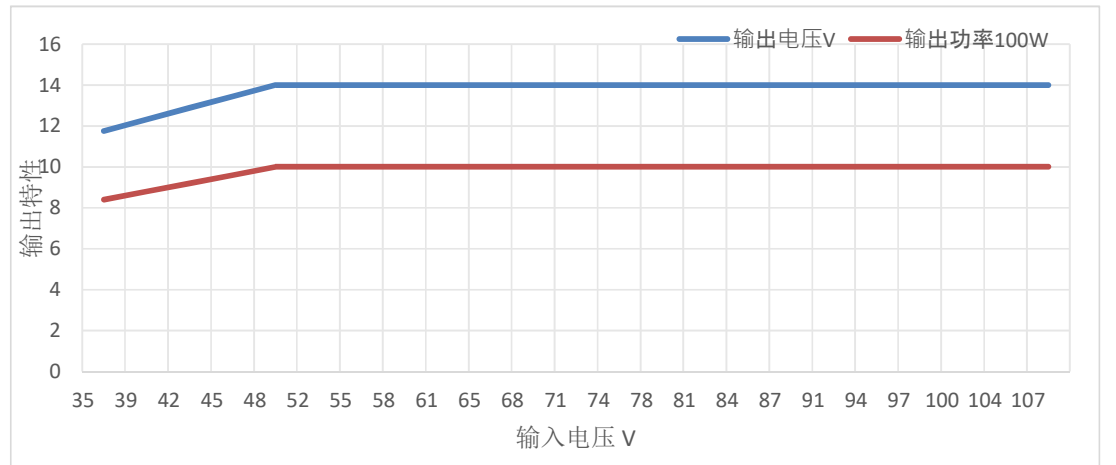

RDIP2144 external characteristic curve

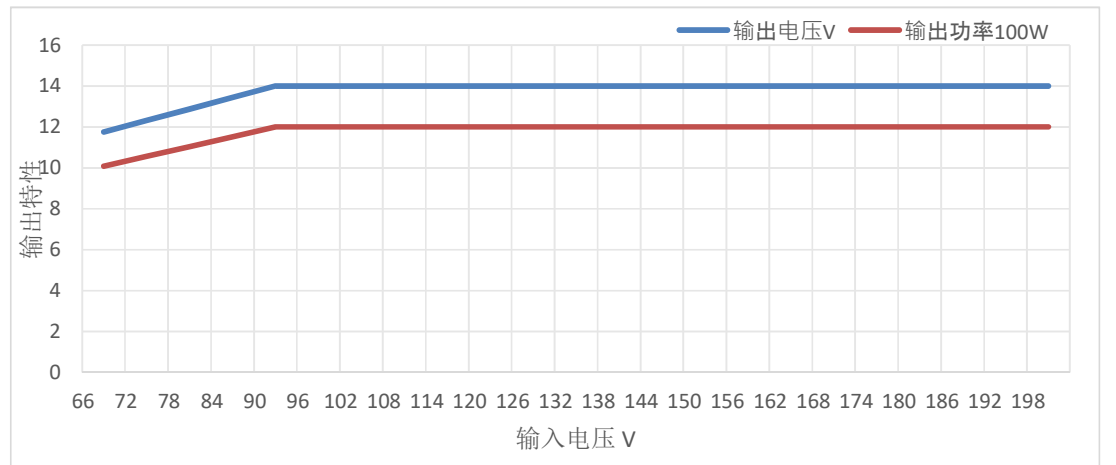

RD1P2360 external characteristic curve

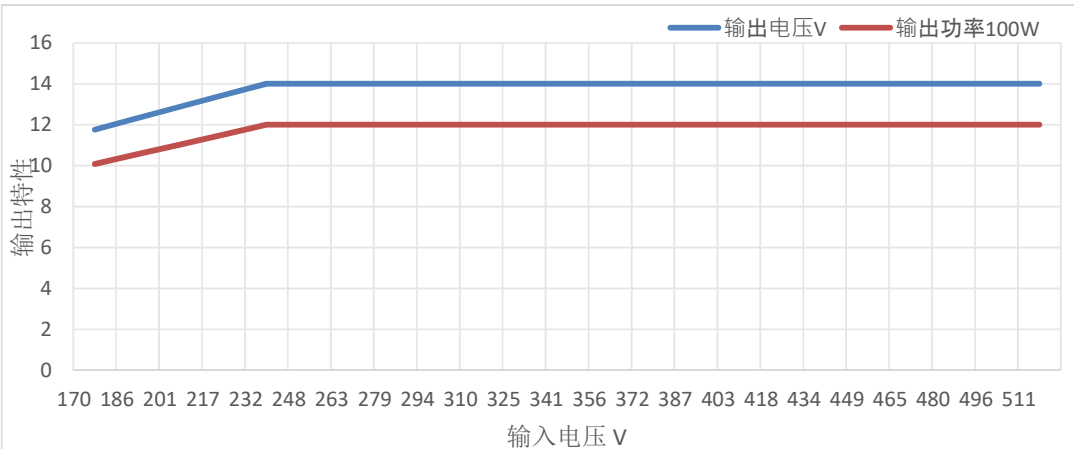

RD1P2540 external characteristic curve

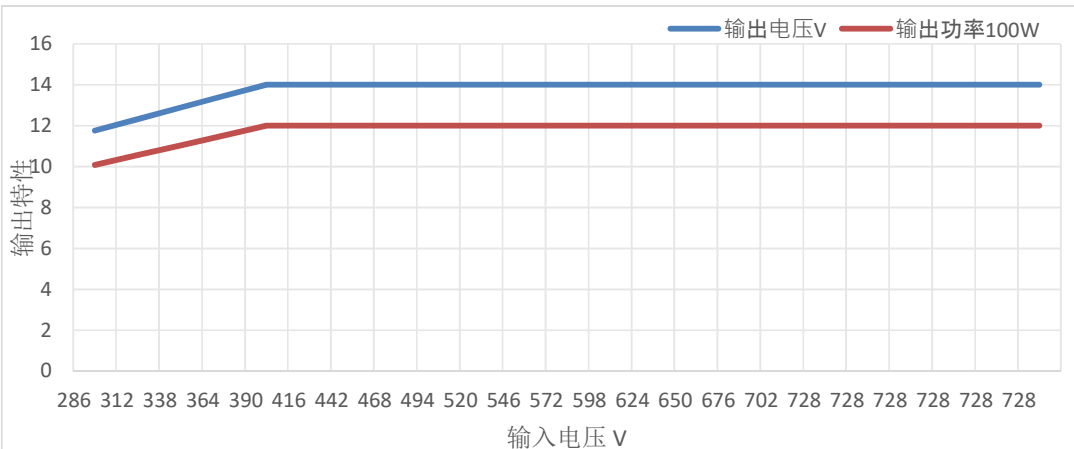

RD1P2144-27 external characteristic curve

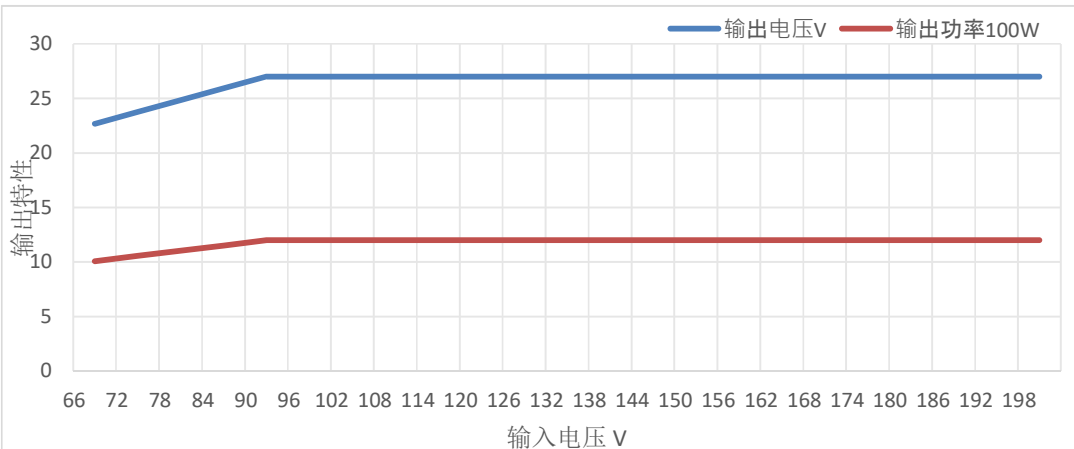

RD1P2360-27 external characteristic curve

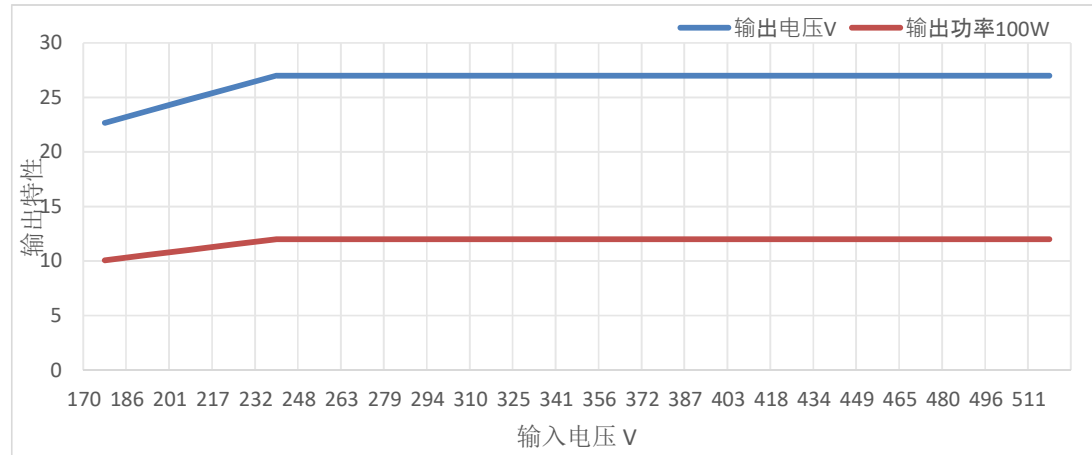

RD1P2540-27 external characteristic curve

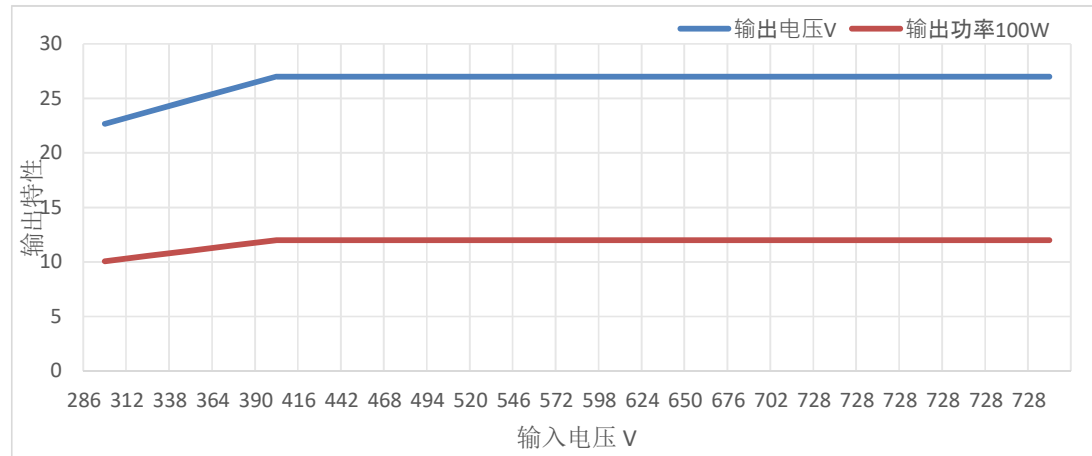

2 External dimensions and weight

2.1 Product size

3D model data: [RD1P00722 V1.2](#)

vertical view

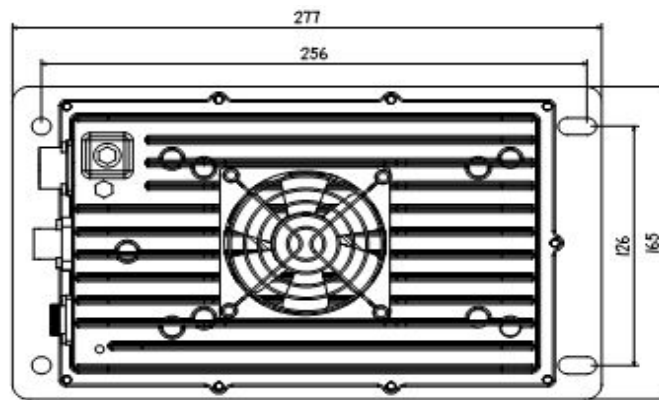

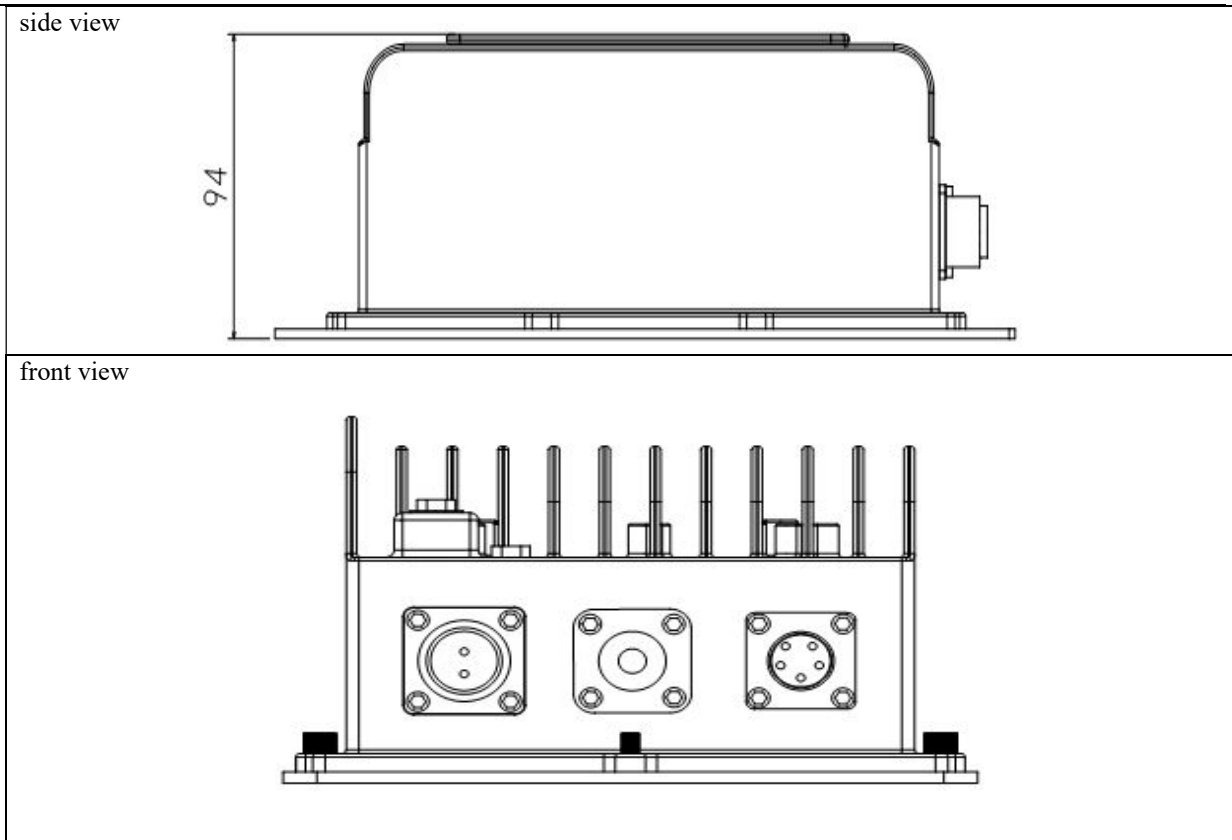

2.2 Product weight

3.5Kg±0.3Kg

3 Definition of connectors and connection terminals

3.1 Connector model and definition

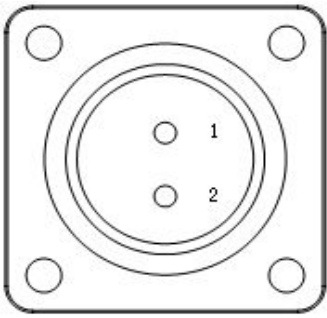
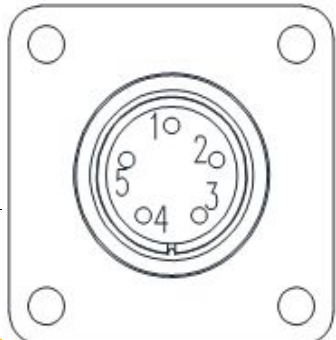
type	Definition of connectors		Connector drawing
input WF20K2Z	Foot position	definition	
	1	Input+	
	2	Input-	
Connector manufacturer		Guangdong Weipu Electric Appliance Co., Ltd	
Regarding the plugin model		WF20J2TE	
signal WF16K5Z	Foot position	definition	
	1	CANH	
	2	CANL	
	3	12V+	
	4	GND	

Product part number	RD1P0 series	
product type	Vehicle mounted DC-DC complete machine	
mounting screw	Installation hole diameter	Φ9
	number	4
	Recommended screw models	M8 * 10 hexagonal combination screw

Install and fix this product

Align the installation holes, tighten the fastening screws, and secure the power supply.

Tightening distance requirements



During installation, use appropriate torque based on screw size, connection method, etc. Refer to the table below for details:

Specification and model		Tightening torque (torque range: ± 10%)/(unit: Kgf. cm)						
Large category	Subclass	Plastic - Plastic	Steel plastic Copper - Copper	General connection		High density connection		
				Steel - Steel	Copper cast aluminum Steel aluminum profiles Steel Copper	Steel - Steel	Steel cast aluminum Steel Copper	Steel aluminum profiles
Hexagon socket head cap screw	M2		0.8	1.5	1.5	2.5	2.5	1.5
	M2.5		1.6	3	3	5.5	4.5	3
	M3	1.5	3	5.5	5	10	8	6
	M4		6	12	10	16	14	12
	M5		10	20	13	30	28	20
	M6		15	30	28	50	48	30
	M8					80	80	-

4. 3 CAN communication protocol

project	Technical indicators	remarks
Crystal oscillator tolerance	± 0.15%	Within the working temperature range
Communication speed	Configurable through backend software to prevent loss in case of power failure	Tolerance is ± 0.375 Kbit/s
Sampling point	The sampling point should be set at a location close to but no later than 7/8 of the bit time	
transceiver	The maximum transceiver "ring delay" (from transmission to reception) is 300 ns	CAN transceiver should comply with ISO 11898-2 standard
Termination resistor	DC-DC CAN communication circuit communication defaults to no 120 ohm terminal resistance	
Default CAN communication protocol	 车载DCDC默认CAN控制通讯协议 V1.	

4. 4 Background Debugging Software Instructions

Product part number	RD1P0 series	
product type	Vehicle mounted DC-DC complete machine	
Backend software coding	2001 Setup V2.0	
Communication method of backend software	can communication	Baud rate adjustable from 125K/250K/500K
Installation and usage assistance		 上位机使用说明.pdf
Support CAN box Brand 1	1 Beijing Aitai USBCAN-2I 2 Beijing Aitai USBCAN-I	 USBCAN Driver for Windows 10-amd64-1.0.1.exe
Support CAN box Brand 2	TBD	

4.5 Troubleshooting and Confirmation

Fault phenomenon	Common causes of malfunctions	Troubleshooting
Power supply has no output	Abnormal high voltage input (none or reversed connection)	Check if the high voltage input is normal
	Abnormal 12V voltage input port (none, over/under voltage, reversed connection)	Check if the 12V voltage input port is normal
	Output circuit breaker	Check if the output connection is normal
DC-DC no message	The signal connector is not properly connected	Re plug and unplug the signal connector
	Reverse connection of CAN line	Adjust the CAN line sequence
	Communication protocol mismatch	Compare whether the protocol matches
	Baud rate mismatch	Compare whether the baud rate matches
The high-voltage input fuse of the distribution box is damaged Product reporting fault signal	Input short circuit	Check if the high voltage input is normal
	Input over/under voltage, output over/under voltage, over temperature, output short circuit/over-current	Check the input voltage and output for overcurrent/short circuit. Turn off the power and let it stand for 10 minutes. If the fault persists, please contact the manufacturer.
Overheating fault	Air cooled machine: Fan blockage or blocked air duct	Check the fan and air duct
	Water cooled machine: No coolant or coolant temperature too high	Check if the coolant is working properly

5 User Notice and Precautions

Please pay attention to the warning and precautions section before using the product. Incorrect operation may result in electric shock damage to the power supply or cause a fire. Please confirm that you have read the warnings and precautions before using the product.

Warning:

It is strictly prohibited to disassemble the product for maintenance, debugging, or modification without authorization;

When powered on, please keep your hands and face away from the product to avoid accidental injury;

There is high voltage and high temperature inside the product. Please do not touch the internal components as it

may cause electric shock or burns;

If there is any abnormal noise or odor from the power supply during use, please immediately turn off the input;

It is necessary to use connectors that meet the specifications to ensure that all plugs and sockets are securely connected. Loose connections may cause local heating and fire;

Please use the power supply within the technical parameter range. If used beyond the range, it may cause product damage;

Please avoid placing the product in a rainy location for a long time;

Before installation, please confirm that the casing is intact and undamaged. If there is any damage, please replace it immediately or contact the manufacturer.

matters needing attention:

Confirm that the product input/output terminal and signal terminal are connected correctly according to the product manual; When wiring, please cut off the input power and do not plug or unplug connectors with power on;

This power input/output terminal requires an external fuse or other overcurrent protection device;

It is necessary to consider the potential electrical hazards at the output end of the product during use, to ensure that end product users do not come into contact with the product; Terminal equipment manufacturers must design corresponding protection schemes to ensure that there is no danger caused by accidental contact of power terminals by engineering personnel or tools during operation;

Once the safety protection of the equipment is damaged, the equipment must stop working and refer to relevant maintenance regulations for handling.

When power equipment is switched from a cold environment to a warm environment, condensation may cause leakage hazards, so grounding requirements must be strictly followed;

Only qualified personnel can connect the equipment to the power source.

Cut off the power supply and stop the machine for five minutes to allow sufficient discharge time for the capacitor before maintenance can be carried out on the power equipment.

Pay attention to safety: Avoid touching places with safety warning signs and high-voltage signs with your hands to prevent electric shock and burns.

6 Reference standards and specifications

GB 14023-2011 Limits and measurement methods for radio disturbance characteristics of vehicles, ships and devices driven by internal combustion engines

GB/T 17626.2-2006 Electromagnetic Compatibility Testing and Measurement Techniques - Electrostatic Discharge Immunity Test

GB/T 17626.3-2006 Electromagnetic Compatibility Testing and Measurement Techniques - Radio Frequency Electromagnetic Field Radiation Immunity Test

GB/T 17626.4-2008 Electromagnetic compatibility - Testing and measurement techniques - Electrical fast transient burst immunity test

GB/T 17626.5-2008 Electromagnetic Compatibility - Testing and Measurement Techniques - Surge (Impulse) Immunity Test

GB/T 17619 1998 Limits and measurement methods for electromagnetic radiation immunity of electronic and electrical components of motor vehicles

GB/T 18384.3-2015 Safety Requirements for Electric Vehicles Part 3: Personnel Electric Shock Protection

GB/T 18387-2008 Limits and measurement methods for electromagnetic field emission intensity of electric vehicles, broadband, 9KHz to 30MHz

GB/T 18487.2-2001 Conductive Charging System for Electric Vehicles - Connection Requirements between Electric Vehicles and AC/DC Power Sources (doc)

GB/T 18487.3-2001 Conductive Charging System for Electric Vehicles - AC/DC Chargers (Stations) for Electric Vehicles (doc)

GB/T 18488.1-2015 Drive Motor Systems for Electric Vehicles Part 1: Technical Conditions

GB/T 18655-2010 Measurement, ship and internal combustion engine radio disturbance characteristics - Limits and measurement methods for protecting on-board receivers

GB/T 19826-2014 General Technical Conditions and Safety Requirements for DC Power Supply Equipment in Power Engineering

GB/T 21437.2-2008 Road vehicles - Electrical disturbances caused by conduction and coupling - Part 2: Transient electrical conduction along power lines

GB/T 2423.1-2008 Environmental Testing for Electric and Electronic Products - Part 2: Test Methods - Test A: Low Temperature

GB/T 2423.2-2008 Environmental Testing for Electric and Electronic Products - Part 2: Test Methods - Test B: High Temperature

GB/T 2423.3-2006 Basic Environmental Testing Procedures for Electrical and Electronic Products - Test Ca: Constant Damp Heat Test Method;

GB/T 2423.4-2008 Basic Environmental Testing Procedures for Electrical and Electronic Products - Test Db: Alternating Damp Heat Test Method

GB/T 2423.5-1995 Environmental Testing for Electrical and Electronic Products, Part 2: Test Methods/Test Ea and Guidelines: Impact

GB/T 2423.6-1995 Environmental Testing for Electrical and Electronic Products, Part 2: Test Methods/Test Ea and Guidelines: Collision

GB/T 2423.8-1995 Environmental Testing for Electrical and Electronic Products, Part 2: Test Methods/Test Ed: Free Drop

GB/T 2423.10-2008 Environmental Testing for Electrical and Electronic Products, Part 2: Test Methods/Test Fc and Guidelines: Vibration (Sinusoidal)

GB/T 2423.22-2012 Environmental testing for electrical and electronic products, Part 2: Test N: Temperature variation

GB/T 24347-2009 Electric Vehicle DC/DC Converter

GB 4208-2008 Degrees of Protection Provided by Enclosures (IP Code)

QC/T 413-2002 Basic Technical Conditions for Automotive Electrical Equipment

GB 9254-2008 Radio disturbance limits and measurement methods for information technology equipment

7 Packaging, transportation, and storage package

The product packaging information is as follows:

Packaging quantity and box information	Single unit net weight Kg	3.5Kg
	Outer dimensions of packaging box mm	390*295*157
	Quantity of complete machines per box	2
	Total weight after packaging Kg	9Kg

The packaging box has the product name, product model, and manufacturer name; The technical documents supplied with the product in the packaging box should include the product's factory certificate of conformity.

The product should be transported in a sturdy packaging box, and the outside of the box should comply with relevant national standards and have signs such as "Handle with Care" and "Moisture proof". The packaging box containing the product is allowed to be transported by various means of transportation. During transportation,

direct rain, snow, and mechanical impact should be avoided. And attach the transportation mark, as shown in Figure 7-2 below:



shipping mark

keep in storage

When the product is not in use, it should be stored in the packaging box. The warehouse environment temperature should be -10-40 °C and the relative humidity should not exceed 80%. Harmful gases, flammable, explosive products, and corrosive chemicals are not allowed in the warehouse, and there should be no strong mechanical vibration, impact, or strong magnetic field effects. The packaging box should be placed at least 20cm above the ground and at least 50cm away from walls, heat sources, windows, or air inlets. The storage period under these regulations is generally 2 years, and re inspection should be conducted after exceeding 2 years.

The product should be stored in a well ventilated and dry place. At the same time, it is necessary to avoid high temperature sources, fire sources, and chemicals. Store neatly and avoid throwing or smashing.

8 Version Updated Record

date	version	Reason for Change	notes
2021/03/13	V1.0		
2021/11/07	V1.1	Update plugins	
2022/12/12	V1.2	Update the shell	
2024/05/06	V1.3	Update the shell	